

reinforced besser block retaining walls

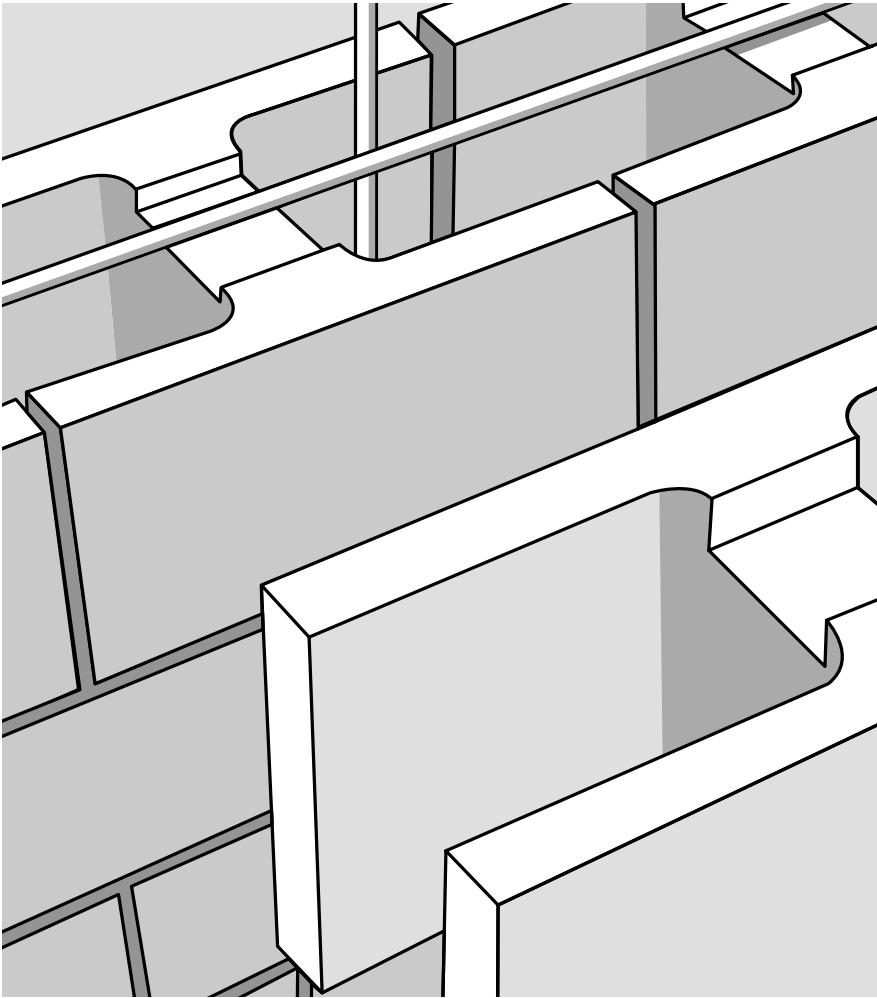

Preface

The designs shown in the brochure are based on limit state design in accordance with the provisions of AS4678-2002 Earth retaining structures standard including Amendment 1, 2003. The designs are hereby certified by Hanson Building Products Pty Ltd ABN 31 009 687 521.

The design details provided in this brochure have been prepared by Hanson specifically for Hanson blocks and are applicable only to retaining walls using Hanson products for residential or light commercial applications up to 3.0m high. For higher and/or more complex applications it is recommended reference be made to the Concrete Masonry Association of Australia document Reinforced Concrete Masonry Cantilever Retaining Walls – Design and Construction Guide MA51, Amended July 2003.

Introduction

Reinforced Besser Block Retaining and Basement Walls consist of a reinforced concrete base which anchors the wall against overturning and sliding, and a stem of Besser blocks. The stem is reinforced with steel bars placed vertically and horizontally, and all cores in the blocks are filled with semi-fluid concrete, known as 'grout'. The vertical reinforcing bars in the cores are lapped with shorter 'starter bars' embedded firmly in the reinforced concrete base using a hob to correctly locate the bars. These short bars allow easier blocklaying, and the longer bars are put in after all blocks are laid and before grouting. The length of the lap is critically important and must be shown on the drawings

Contents

Preface	i
Introduction	i
1.0 Retaining walls	1
1.1 Designs for reinforced retaining wall types	1
1.2 Loading Conditions	2
1.2.1 Retaining Walls	2
1.3 Material Specifications	2
1.4 Soil Classification	2
1.5 Wall Foundation	2
1.6 Infill Soil and Retained Soil	2
1.7 Drainage Systems	3
1.8 Water Penetration	3
1.9 Exploded View of Construction	3
1.10 How to Build the Wall	4
1.10.1 Preliminary	4
1.10.2 Base and Hob	4
1.10.3 Block Laying	4
1.10.4 Grouting	4
1.11 Tanking	4
1.12 Infill Soil and Drainage	4
1.13 Design Details for Wall Type 1	5
1.13.1 Level Surface Wall Layout	5
1.13.2 Sloping Surface up to 1 in 4 Wall Layout	6
1.13.3 Base and Key Sizes	7
1.13.4 Reinforcement Details	7
1.14 Design Details for Wall Type 2	8
1.14.1 Level Surface Wall Layout	8
1.14.2 Sloping Surface up to 1 in 4 Wall Layout	9
1.14.3 Base and Key Sizes	10
1.14.4 Reinforcement Details	10
2.0 Basement Walls	11
2.1 General	11
2.2 Drainage	11
2.3 Tanking	11
2.4 How to build the wall	11
2.5 Designs for reinforced basement wall types	11
2.6 Besser block basement wall design details for supporting a concrete floor	12
2.7 Besser block basement wall design details for supporting a timber floor	12
2.8 Basement walls	13
Glossary	13

1.0 Retaining walls

1.1 Designs for reinforced retaining wall types

Retaining walls up to 3.0 m high.

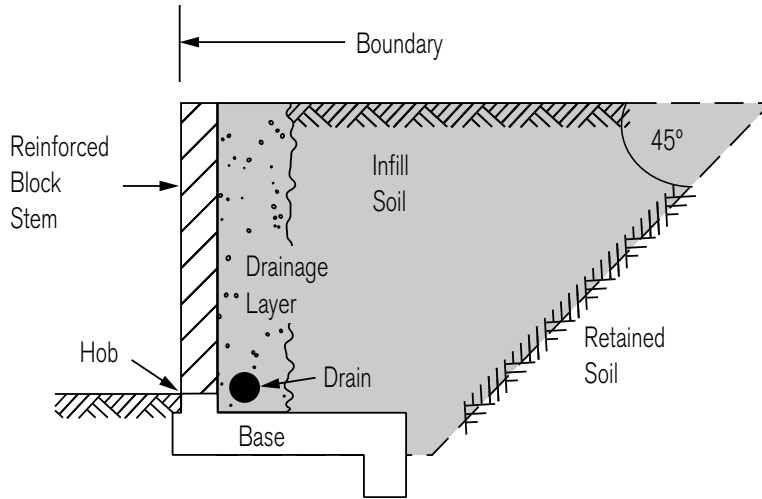

WALL TYPE 1

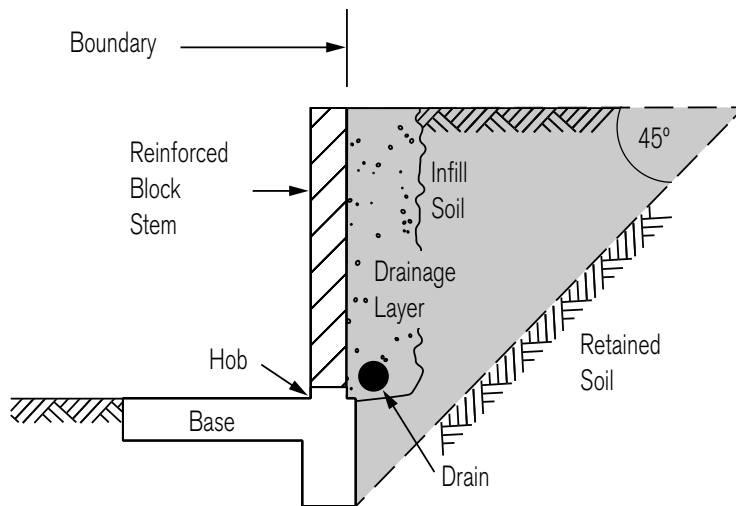

WALL TYPE 2

Note: Diagrams not to scale.

1.2 Loading conditions

1.2.1 Retaining walls

These tables cover four loading conditions:

- Level surface with 2.5 kPa surcharge for walls up to 1.5 m high.
- Level surface with 5.0 kPa surcharge for walls over 1.5 m high.
- Sloping surface up to 1:4 with 2.5 kPa surcharge for walls up to 1.5 m high.
- Sloping surface up to 1:4 with 5.0 kPa surcharge for walls over 1.5 m high.

- Notes:
- 1 300 mm of soil or a private driveway imposes a load of approximately 5 kPa.
 - 2 Sloping surface steeper than 1:4 is not included in this brochure.

1.3 Material specifications

In calculating these tables, the following material specifications were adopted:

Besser Block	f'_{uc} =	15 MPa in accordance with AS 4455 - 1997
Mortar Class M3		Cement 1 : Lime 1 : Sand 6
	OR	Cement 1 : Lime 0 : Sand 5
		plus cellulose-based water thickener
Concrete base	$f'c$ =	25 MPa
Reinforcement		Grade 500 N
Grout	$f'c$ =	20 MPa with a pourable consistency and a cement content not less than 300 kg/m ³

Where possible, use ready-mixed grout and specify when ordering that it is for filling blockwork. If the grout is mixed on site, use the following proportion:

Cement	-	1 part
Hydrated lime	-	Up to 1/10th part
Mortar sand	-	3 parts
10 mm aggregate	-	Up to 2 parts

(10 mm aggregate should be rounded gravel where possible.)

Grout should be mixed in a tilting drum paddle mixer and should flow freely without separation of the aggregate.

1.4 Soil classification

To simplify the following design tables only one type of soil has been used throughout for both infill soil and retained soil. It is classified as an average soil and would be typical of a wide range of insitu soils and would normally include; stiff sandy clays, gravelly clays, compact clayey sand and sandy silts, compacted clay fill (Class II).

The characteristic soil property has been reduced by the uncertainty factors below and upon which the designs have been based:

Uncertainty factor for drained cohesion, $\Phi_{uc} = 0.70$

Uncertainty factor for drained internal friction angle, $\Phi_{u\phi} = 0.85$

ie: $\Phi^* = \tan^{-1} (\Phi_{u\phi} (\tan \phi'))$

Characteristic soil parameters		Design soil parameters	
internal friction angle ϕ' (degrees)	cohesion c' (kPa)	internal friction angle ϕ^* (degrees)	cohesion c^* (kPa)
27	3	23	2

1.5 Wall foundation

The tables have been based on a foundation soil as described above and which must be excavated to sufficient depth to expose undisturbed material which is firm and dry.

Should a designer wish to analyse a retaining wall built on a different foundation, base dimensions different from the tabulated values could be appropriate.

If any of the following foundation conditions exist: softness, poor drainage, filled ground, organic matter, variable conditions, heavily cracked rock, aggressive soils, then experienced professional engineering advice should be obtained.

1.6 Infill soil and retained soil

These tables have been calculated for infill soil and retained soil of soil classification shown above.

Note the following poor quality soils are not allowed for in the tables; soft and firm clay of medium to high plasticity, silty clays, loose variable clayey fill, loose sandy silts.

If these soils are considered for use or aggressive groundwater exists an experienced professional engineer should be consulted and separate designs be obtained.

1.7 Drainage systems

It is essential that steps be taken to prevent the soil behind the wall from becoming saturated. These steps should include:

- Sealing the soil surface – this can be done by covering it with a compacted layer of material with low permeability. The surface should be sloped towards an open drain.
- A drainage system within the soil – this should preferably be achieved by placing gravel to a width of approximately 300mm immediately behind the wall with a continuous 100mm diameter slotted pvc agricultural pipe with geo fabric sock located at the base of the wall. The outlets from the pipe must be beyond the ends of the wall unless the pipe is connected to a proper storm water drainage system. For higher walls, or in cases where excessive ground water exists it may be necessary to provide another agricultural pipe drain at mid height of the wall.

If it is not possible to discharge the drains beyond the end of the wall, weep-holes may be provided (see items for block laying following). In this case, a collecting system (e.g. spoon drains) must discharge the water into a drainage system to prevent saturation of the ground in front of the wall.

A subfloor drainage system is advisable in basements to prevent hydrostatic pressure under the floor slab.

1.8 Water penetration

If considered necessary to reduce the passage of water through the wall, for aesthetic or other reasons such as aggressive ground water, the earth face of the wall should be treated using appropriate sealing techniques. (See notes on tanking.)

1.9 Exploded view of construction

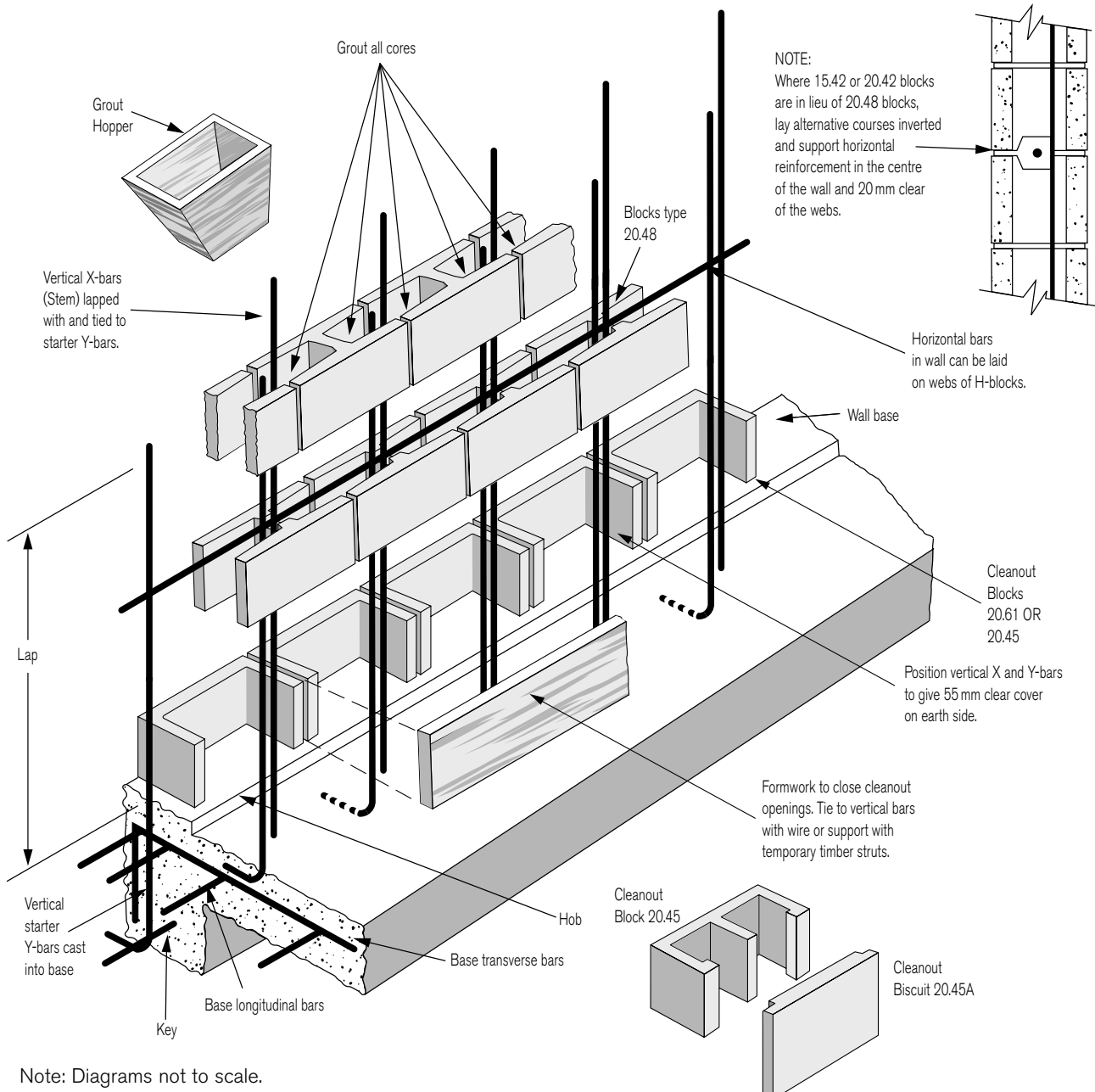

Note: Diagrams not to scale.

1.10 How to build the wall

1.10.1 Preliminary

- Excavate to a satisfactory foundation.
- Arrange for supply of materials to the specifications given previously.

1.10.2 Base and hob

- Form the base and hob to the required dimensions and levels as shown in tables.
- Place the base reinforcement as shown in the diagrams, securely fix the starter bars for the vertical reinforcement (Y-bars) 55 mm from the back face of the wall, in the correct positions relative to the block cores to be reinforced by using the top front edge of the hob as a positioning reference point.
- Place the base concrete, preferably using ready-mixed concrete, and compact thoroughly by rodding, spading or vibrating. Wood float finish any surface to be exposed permanently. Take care not to dislodge reinforcement.

1.10.3 Block laying

Block laying procedure follows that of the normal practice for building unreinforced walls but, includes the additional requirement of locating the first course directly on top of a hob which is used to accurately locate the starter bars. The mortar mix used should be cement 1 part, lime 1 part, sand 6 parts or cement 1 part, sand 5 parts plus water thickener. These parts should be accurately measured by volume (e.g. a bucket). The sand used should be clean pit sand, masonry or plasterer's sand. The use of plasticising additives is permitted. Where they are used, the dosage rate must not exceed that recommended by the supplier as this will drastically reduce the mortar strength. Detergent should never be used.

Recommendations specifically applicable to reinforced concrete block retaining walls follow:

- Cleanout openings should be provided in the bottom course using either 20.61 blocks plus timber formwork at the front or 20.45 blocks plus 20.45 A biscuits to permit removal of mortar fins and other debris, and to allow positioning and tying of vertical reinforcement. These openings must be closed before grouting.
- Above the first course, the use of 15.48, 20.48 and 30.48 H-Blocks is recommended because they are easier to fill with grout and provide required protection of the reinforcement. 15.42 and 20.42 blocks may be used in lieu of H-Blocks and these blocks require less grout for filling. However, they must be laid with alternative courses inverted so as to provide grout cover to longitudinal reinforcement, which must be lifted 20 mm clear of the web of the block by using stirrups or other supports (see diagram).
- Mortar projecting into the cores should be removed, either as the blocks are laid, or by rodding after the mortar has set. Debris should be removed from the cores through the cleanout openings.
- When the wall is to be tanked, the mortar joints on that face should be struck flush and cleaned.
- Weepholes can be provided by passing 50 mm diameter upvc pipes holes through the hob at 1200 mm centres.
- Reinforcement must be positioned accurately (refer to above),

and tied securely before placing concrete or grout. Vertical reinforcing bars, including starter bars, should be as close to the back face of the wall as possible, consistent with 55 mm cover requirements.

1.10.4 Grouting

- Close cleanout openings.
- Place grout. It is recommended that whenever available, ready-mixed grout to workability specifications given in AS3700 2001 should be used. Site-mixed grout, if used, should be mixed thoroughly in a tilting drum type paddle mixer to the same specification as ready-mixed grout.
- All cores should be filled with grout, whether reinforced or not. This is essential to bond and protect horizontal reinforcement, and to give maximum weight for stability.
- The grout should be compacted thoroughly so that voids are not left. Compaction may be by rodding with a plain round bar (do not use main vertical reinforcing bars or other deformed bars) or with a high frequency pencil vibrator, used carefully.

1.11 Tanking

Where the wall is required to be waterproof, for example a basement wall, various proprietary tanking methods are available. One such method is a three coat liquid rubber compound incorporating a special reinforcing fabric for high stressed areas.

Another method is a heavy duty, pliable, waterproof sheet membrane fixed to the wall surface. Surface coatings or sheet membranes must always be used in accordance with the manufacturer's specifications.

1.12 Infill soil and drainage

- Infill soil should not be placed behind the wall until at least ten days after grouting.
- Infill soil should be placed and compacted in layers not more than 200 mm deep. The degree and method of compaction depends on the proposed use of the retaining wall.
- The drainage system should be installed progressively as the infill soil rises.
- The drainage system behind the wall should be connected to the main drainage system.
- For the nominated infill soil in this brochure, it is advisable to seal off the top surface of the infill soil with a semi-impermeable layer of soil or earth. Compact and grade to a gutter to provide surface drainage.

1.13 Design details for wall type 1

1.13.1 Level surface wall layout

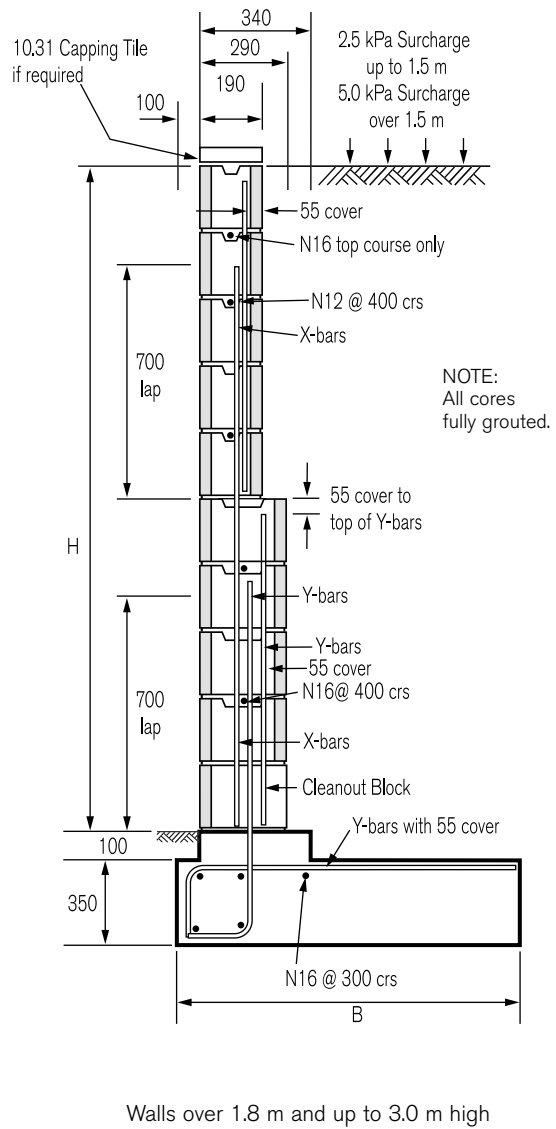
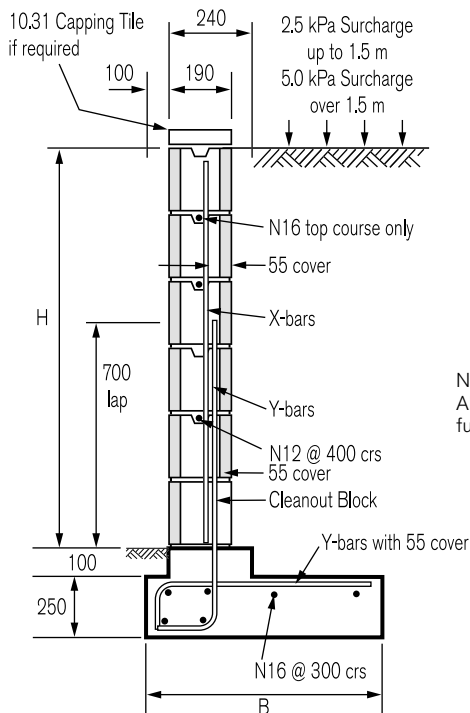
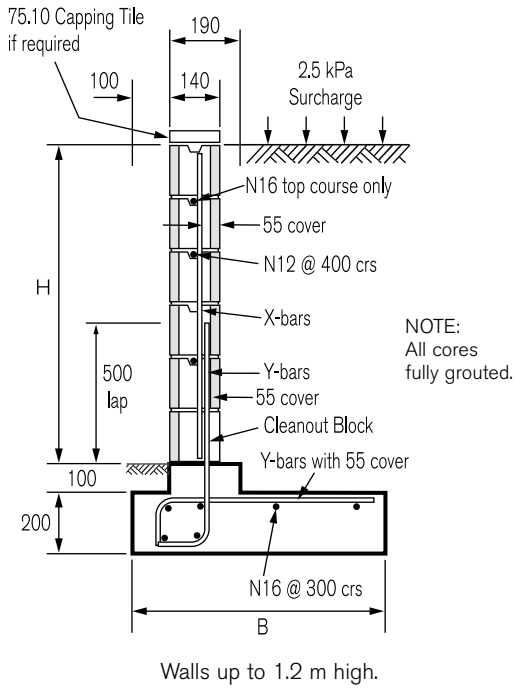

Note: Diagrams not to scale.

wall type 1

1.13.2 Sloping surface up to 1 in 4 wall layout

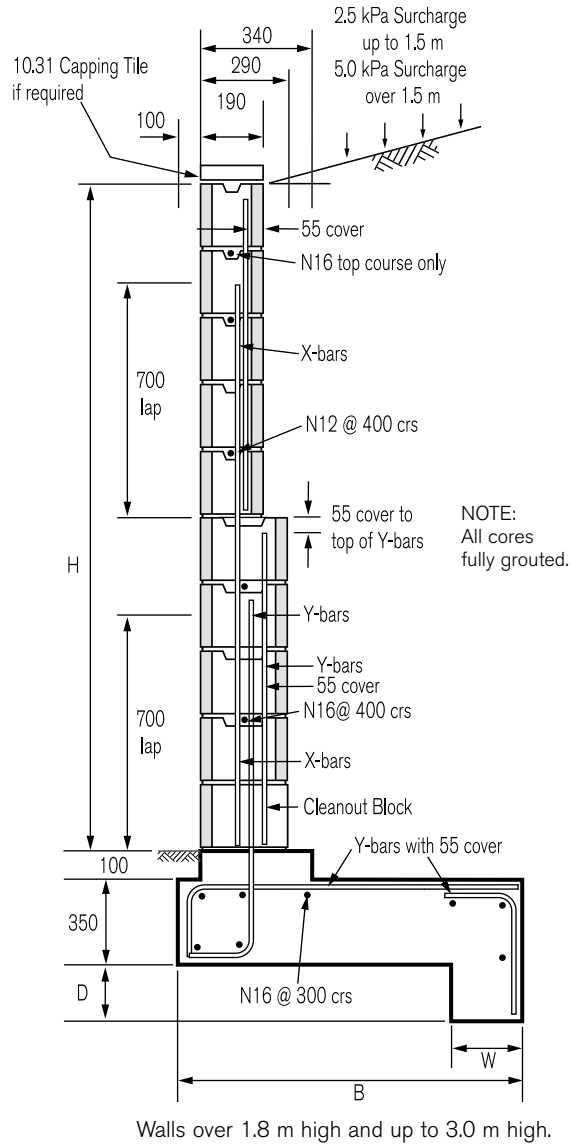
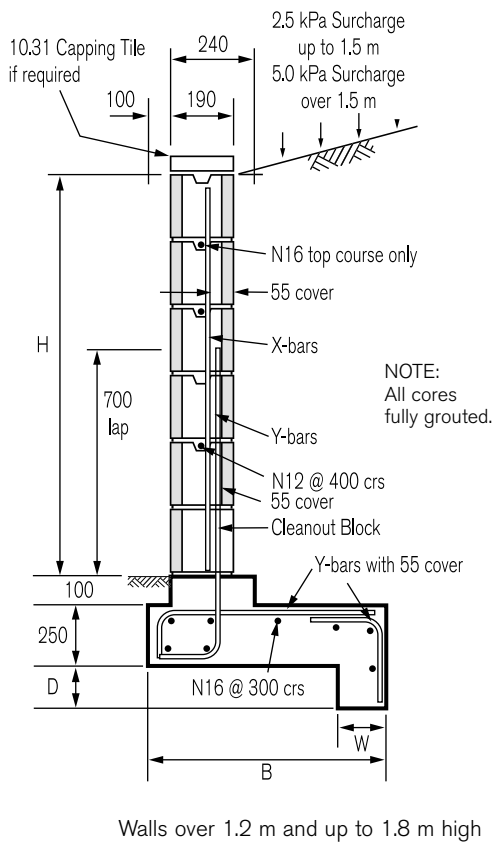
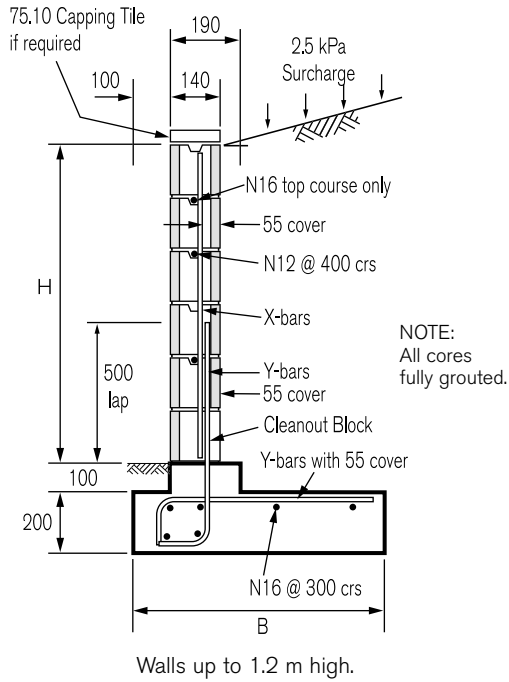

Note: Diagrams not to scale.

wall type 1

1.13.3 Base and key sizes

WALL HEIGHT 'H'	BASE WIDTH 'B'				KEY WIDTH 'W'	KEY DEPTH 'D'
	SURFACE SLOPE				SURFACE SLOPE	
	LEVEL WITH		UP TO 1 IN 4 WITH		UP TO 1 IN 4 WITH	
	2.5 kPa Surcharge	5.0 kPa Surcharge	2.5 kPa Surcharge	5.0 kPa Surcharge	5 kPa Surcharge	
600	500	–	700	–	–	–
800	600	–	800	–	–	–
1000	700	–	1000	–	–	–
1200	850	–	1200	–	–	–
1400	1000	–	1400	–	–	–
1600	–	1300	–	1800	200	200
1800	–	1450	–	2200	200	250
2000	–	1650	–	2400	300	250
2200	–	1800	–	2700	300	300
2400	–	2000	–	2900	300	300
2600	–	2100	–	3200	300	350
2800	–	2250	–	3400	300	350
3000	–	2450	–	3700	300	400

- Notes:
1. No key required for level surface slope walls.
 2. All dimensions in millimetres.
 3. 300 mm of soil or a private driveway imposes a surcharge load of approximately 5 kpa.
 4. 2.5 Kpa surcharge applies up to 1.5 m.
 5. 5.0 Kpa surcharge applies over 1.5 m.

1.13.4 Reinforcement details

TOTAL WALL HEIGHT 'H'	WALL HEIGHT			REINFORCEMENT			
	HEIGHT OF 150 SERIES BLOCK	HEIGHT OF 200 SERIES BLOCK	HEIGHT OF 300 SERIES BLOCK	SURFACE SLOPE LEVEL		SURFACE SLOPE LEVEL	
				X-Bar	1 : 4 X-Bar	Y-Bar	1 : 4 Y-Bar
600	600	–	–	N12	N12	N12	N12
800	800	–	–	N12	N12	N12	N12
1000	1000	–	–	N12	N12	N12	N12
1200	1200	–	–	N12	N12	N12	N12
1400	–	1400	–	N16	N16	N16	N16
1600	–	1600	–	N16	N16	N16	N16
1800	–	1800	–	N16	N16	N16	N16
2000	–	1800	200	N16	N16	N16	N16
2200	–	1800	400	N16	N16	N16	N16
2400	–	1800	600	N16	N16	N16	N16
2600	–	1800	800	N16	N16	N16	N16
2800	–	1800	1000	N16	N16	N16 @ 200	
3000	–	1800	1200	N16	N16	N16 @ 200	

- Notes:
1. All bars are to be at 400 mm centres unless otherwise stated.
 2. All bars to have 55 mm cover from outside concrete surface.
 3. All dimensions in millimetres.

wall type 1

1.14 Design details for wall type 2

1.14.1 Level surface wall layout

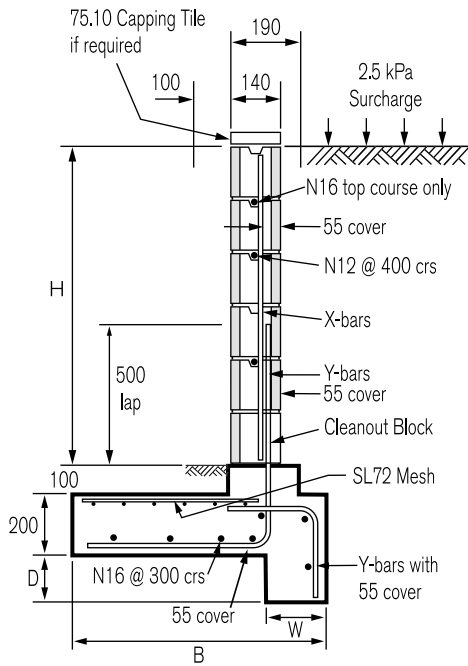

Walls up to 1.2 m high

NOTE:
All cores
fully grouted.

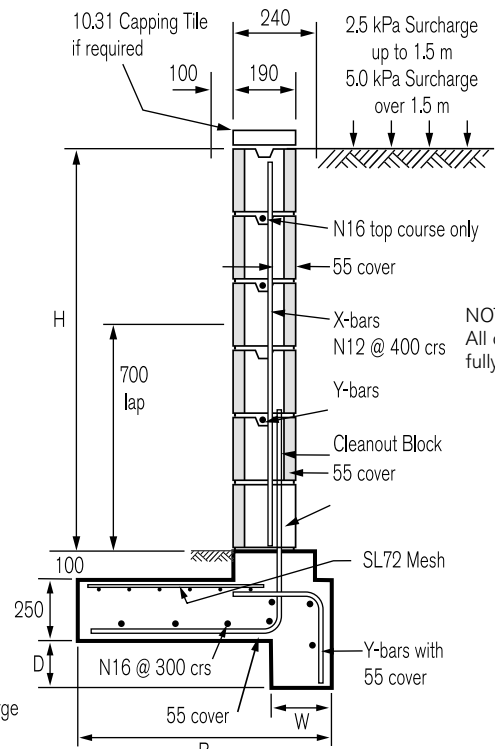

Walls over 1.2 m and up to 1.8 m high

NOTE:
All cores
fully grouted.

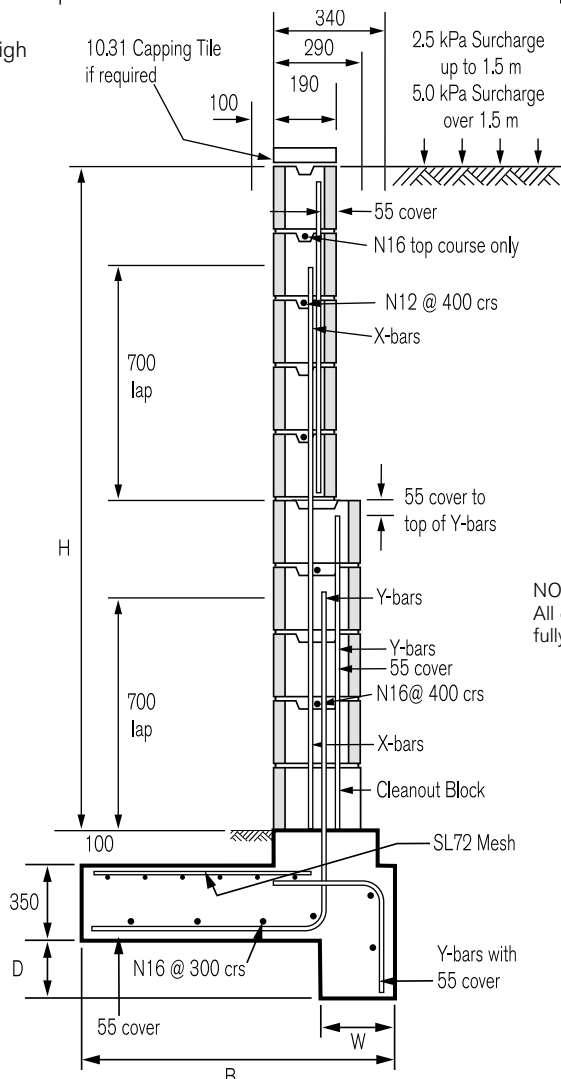

Walls over 1.8 m high and up to 3.0 m high.

NOTE:
All cores
fully grouted.

Note: Diagrams not to scale.

wall type 2

1.14.2 Sloping surface up to 1 in 4 wall layout

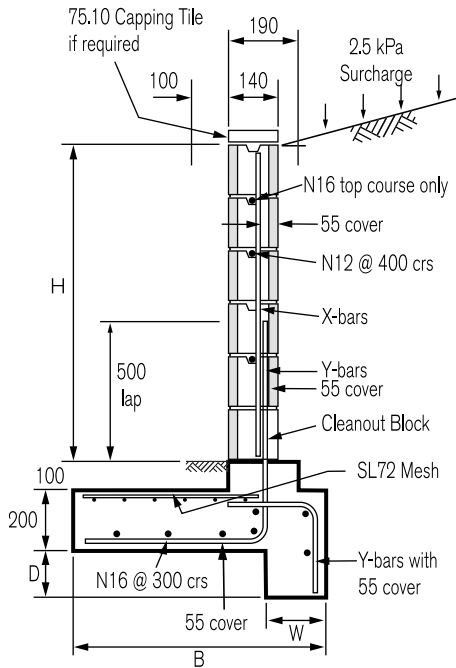

Walls up to 1.2 m high

NOTE:
All cores
fully grouted.

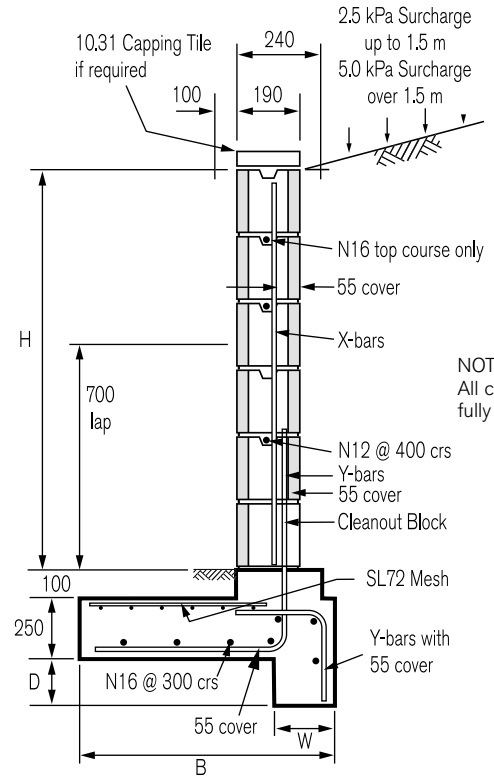

Walls over 1.2 m and up to 1.8 m high

NOTE:
All cores
fully grouted.

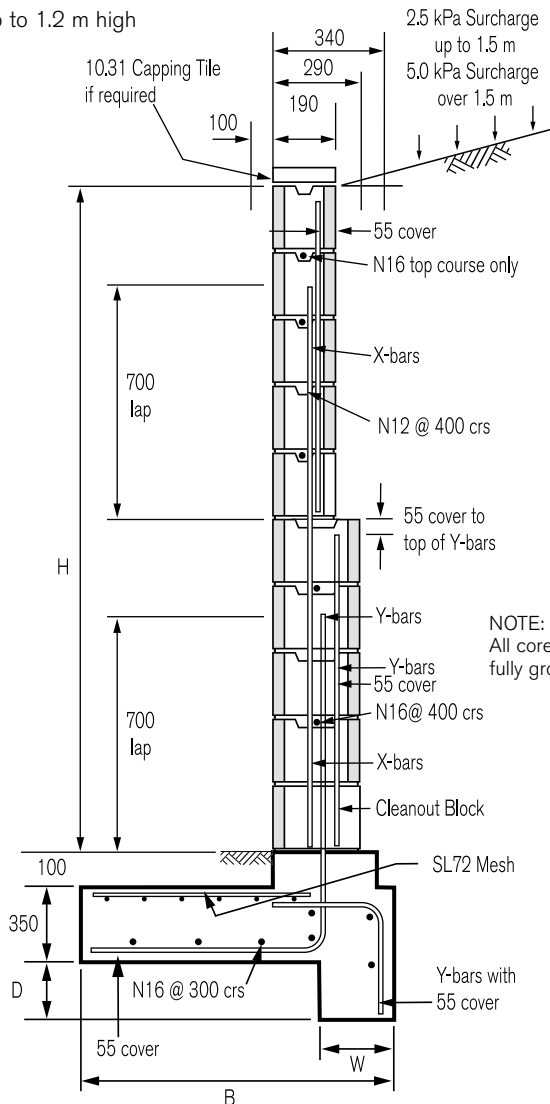

Walls over 1.8 m high and up to 3.0 m high.

NOTE:
All cores
fully grouted.

Note: Diagrams not to scale.

wall type 2

1.14.3 Base and key sizes

WALL HEIGHT 'H'	BASE WIDTH 'B'				KEY WIDTH 'W'		KEY DEPTH 'D'	
	SURFACE SLOPE				SURFACE SLOPE			
	LEVEL WITH		UP TO 1 IN 4 WITH		LEVEL	1 IN 4	LEVEL	1 IN 4
	2.5 kPa Surcharge	5.0 kPa Surcharge	2.5 kPa Surcharge	5.0 kPa Surcharge				
600	500	–	700	–	150	–	100	
800	800	–	900	–	–	–	200	
1000	800	–	1100	–	150	200	300	
1200	1000	–	1400	–	200	300	400	
1400	1100	–	1500	–	200	350	500	
1600	–	1600	–	2200	350	500	700	
1800	–	1900	–	2400	400	550	800	
2000	–	2000	–	2600	400	550	800	
2200	–	2200	–	2900	500	600	900	
2400	–	2400	–	3200	550	700	1000	
2600	–	2700	–	3500	600	750	1100	
2800	–	2900	–	3700	600	800	1200	
3000	–	3100	–	4000	700	900	1300	

- Notes:
1. All dimensions in millimetres.
 2. 300 mm of soil or a private driveway imposes a surface load of approximately 5 kpa.
 3. 2.5 Kpa surcharge applies up to 1.5 m.
 4. 5.0 Kpa surcharge applies over 1.5 m.

1.14.4 Reinforcement details

TOTAL WALL HEIGHT 'H'	WALL HEIGHT			REINFORCEMENT			
	HEIGHT OF 150 SERIES BLOCK	HEIGHT OF 200 SERIES BLOCK	HEIGHT OF 300 SERIES BLOCK	SURFACE SLOPE		SURFACE SLOPE	
				LEVEL	1 : 4	LEVEL	1 : 4
				X-Bar	X-Bar	Y-Bar	Y-Bar
600	600	–	–	N12	N12	N12	N12
800	800	–	–	N12	N12	N12	N12
1000	1000	–	–	N12	N12	N12	N12
1200	1200	–	–	N12	N12	N12	N12
1400	–	1400	–	N16	N16	N16	N16
1600	–	1600	–	N16	N16	N16	N16
1800	–	1800	–	N16	N16	N16	N16
2000	–	1800	200	N16	N16	N16	N16
2200	–	1800	400	N16	N16	N16	N16
2400	–	1800	600	N16	N16	N16	N16
2600	–	1800	800	N16	N16	N16	N16
2800	–	1800	1000	N16	N16	N16 @ 200	
3000	–	1800	1200	N16	N16	N16 @ 200	

- Notes:
1. All bars are to be at 400 mm centres unless otherwise stated.
 2. All bars to have 55 mm cover from outside concrete surface.
 3. All dimensions in millimetres.

wall type 2

2.0 Basement walls

2.1 General

The foundation slab of a basement can be modified to provide an efficient footing for a retaining wall. In addition, a concrete floor slab will provide a 'prop' to the top of the wall, simplifying the wall details compared to a timber floor.

All infill materials must be with granular material. Details of typical basement walls are shown in the following figures.

2.2 Drainage

As with all retaining walls it is critical that the soil is prevented from becoming saturated. Steps to be taken to achieve this include:

- A drainage system within the soil. This should preferably take the form of a 300 mm width of gravel immediately behind the wall with a continuous agricultural pipe located at the base of the wall. The pipe must discharge beyond the ends of the wall.
- Sealing the soil surface. This can be done by placing a compacted layer of low-permeability material over the soil and sloping the surface away from the house.

It is also important to prevent hydrostatic pressure under the floor slab. Where there is the possibility of groundwater under the slab, then a subfloor drainage system is advisable.

2.3 Tanking

Where it is required that the basement be kept dry, a proper tanking system needs to be installed behind the wall before backfilling (refer Chapter 10). An alternative to this is to provide a drain and a false wall in front of the wall (refer alternative detail).

2.4 How to build the wall

Building a Basement wall is essentially the same as building a retaining wall. Please refer to section 1.10 for details on how to build a basement wall.

2.5 Designs for reinforced basement wall types

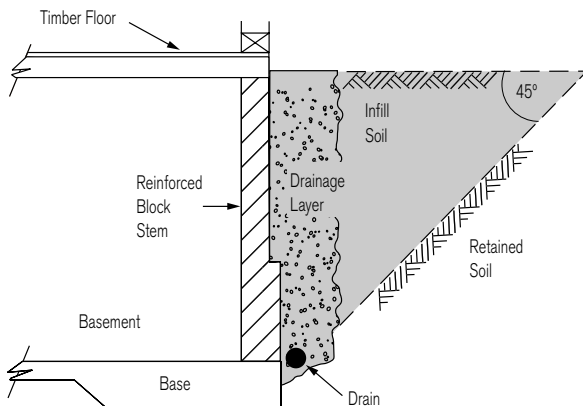

UNPROPPED OR PARTIALLY PROPPED WALL

Basement walls up to 2.7 m high.

Note: Diagrams not to scale.

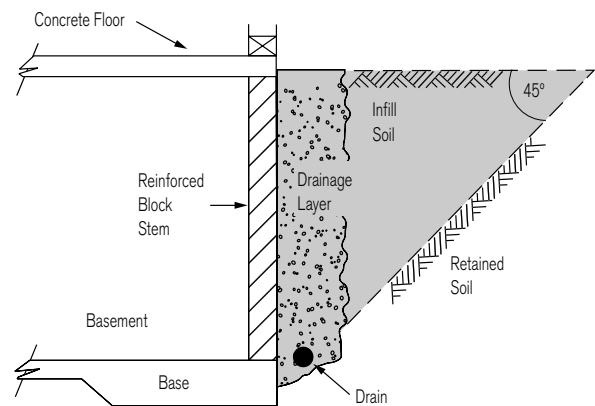

PROPPED WALL

2.6 Besser block basement wall design details for supporting a concrete floor

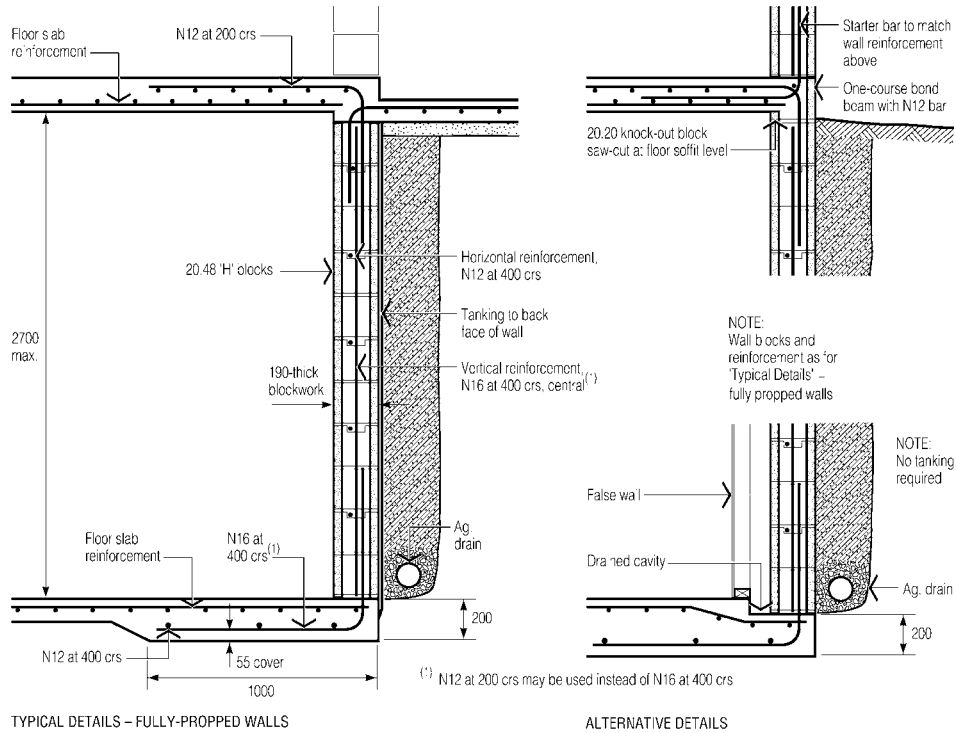

Typical basement wall supporting a concrete floor.

Note: Diagrams not to scale.

2.7 Besser block basement wall design details for supporting a timber floor

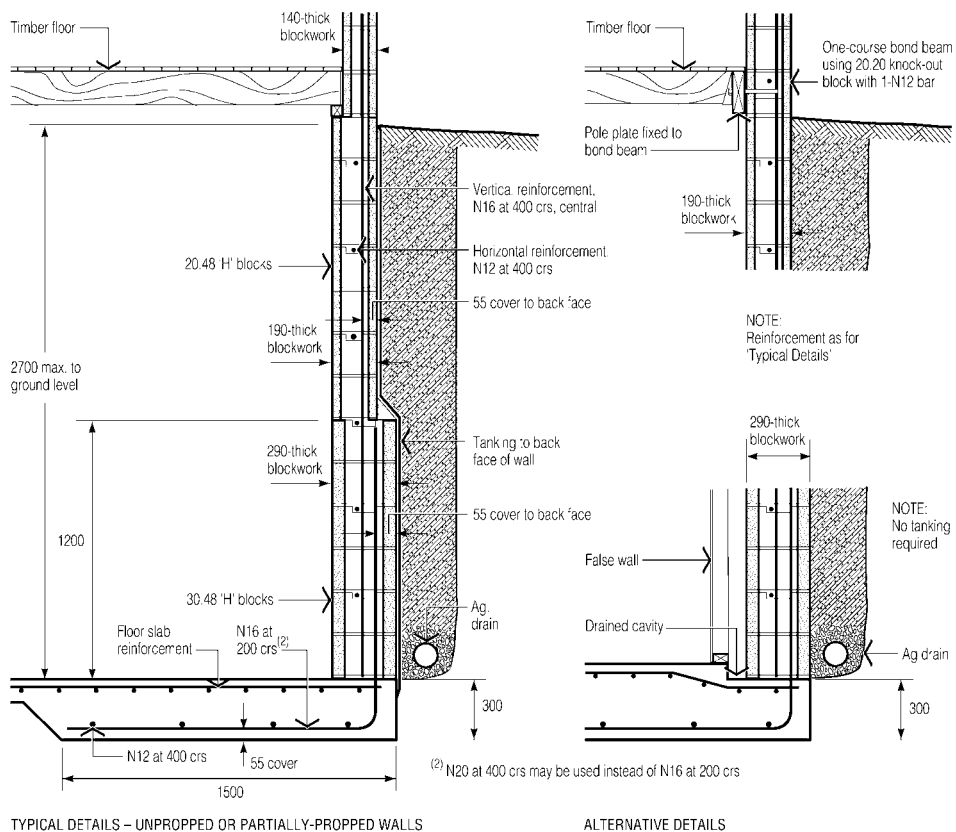

Typical basement wall supporting a timber floor.

Note: Diagrams not to scale.

2.8 Basement walls

These designs are based on a level surface with 5 kPa surcharge. Walls designed as propped must not be backfilled before the concrete floor at the top of the wall is in place.

Important notes

No loadings should be applied (e.g. from footings), within the area of infill soil other than those loadings referred to above.

The area of infill soil is bounded by a line at 45° to the rear of the base as illustrated in chapter 1.

Only one typical soil case is presented. These tables may not provide an ideal solution in a particular case.

For situations other than those covered by the tables, or if there is doubt as to:

- the strength and stability of the foundation material the drainage system needed
- an experienced professional engineer should be consulted for advice.

Glossary

Load and limit states:

Dead load¹

The self-weight of the structure, infill soil, retained soil or rock.

Live load¹

Loads that arise from the intended use of the structure, including distributed, concentrated, impact and inertia loads. It includes construction loads, but excludes wind and earthquake loads.

Surcharge

A uniformly distributed external load. For retaining walls under 1.5m a minimum load of 2.5 kPa. For retaining walls over 1.5m a minimum load of 5 kPa.

Stability limit state

A limit state of loss of static equilibrium of a structure or part thereof, when considered as a rigid body.

Strength limit state

A limit state of collapse or loss of structural integrity of the components of the retaining wall.

Serviceability limit state

A limit state for acceptable in-service conditions. The most common serviceability states are excessive differential settlement and forward movement of the retaining wall.

Components:

Concrete masonry units

Concrete blocks manufactured to provide an attractive, durable, stable face to a retaining wall. The recommended block types are the 15.48, 20.48 and 30.48 'H' blocks.

Retained soil

The natural soil, intended to be retained by a retaining wall.

Foundation soil

The natural soil material under a retaining wall.

Infill soil

The soil material placed behind the retaining wall facing. Often retained soil is used for this purpose.

NOTE: 1 This brochure uses the terminology 'dead load' to indicate permanent loads and 'live load' to indicate imposed loads. This terminology is consistent with the convention adopted in AS 4678-2002.

We'll make it happen

Hanson is a major international aggregates and concrete products company with operations in the USA, UK, Europe, Asia and Australia.

Previously we were known as Pioneer Building Products in New South Wales and Besser in Queensland and Tasmania.

Our focus is on providing the best solutions for our clients through better products and a real can do approach to customer service.

We'll make it happen.